

BOLYMIN

**SPECIFICATIONS FOR
LCD MODULE**

MODEL NO.
BC2004A series
VER.05



FOR MESSRS:

ON DATE OF:

APPROVED BY:

BOLYMIN, INC.

5F, NO.38,Keya Road , Daya Township, Taichung County 42881, Taiwan, R.O.C.

Web Site:<http://www.bolymin.com.tw> **TEL:+886-4-25658689 FAX:+886-4-25658698**

History of Version

| Version | Contents | Date | Note |
|---------|--|------------|-------|
| 01 | NEW VERSION | 2005/10/18 | SPEC. |
| 02 | MODIFY RED BACKLIGHT INFORMATION | 2009/04/08 | |
| 03 | ADD LED array/orange backlight information | 2009/05/05 | |
| 04 | | 2009/06/03 | |
| 05 | ADD Backlight Type | 2011/12/07 | |
| | | | |
| | | | |
| | | | |
| | | | |
| | | | |
| | | | |

CONTENTS

1. Numbering System
2. Precautions in use of LCD Modules
3. General Specification
4. Absolute Maximum Rating
5. Electrical Characteristics
6. Optical Characteristics
7. Interface Pin Function
8. Power supply for LCD Module and LCD operating voltage adjustment
9. Backlight information
10. Quality Assurance
11. Reliability
12. Appendix (Drawing, ST7066U controller data)
 - 12-1 Drawing
 - 12-2 ST7066U controller data
 - 12-2.1 Function description
 - 12-2.2 C.G ROM table. table 2
 - 12-2.3 Instruction table
 - 12-2.4 Timing characteristics
 - 12-2.5 Initializing soft ware of LCM

1. Numbering System

| | | | | | | | | | |
|----------|----------|-------------|----------|---|---|---|---|---|------------|
| <u>B</u> | <u>C</u> | <u>2004</u> | <u>A</u> | : | : | : | : | : | <u>xxx</u> |
| 0 | 1 | 2 | 3 | 4 | 5 | 6 | 7 | 8 | 9 |

| | | |
|----------|--|---|
| 0 | Brand | Bolymin |
| 1 | Module Type | C= character type G= graphic type P= TAB/TCP type O= COG type F= COF type |
| 2 | Format | 2002=20 characters, 4 lines 12232= 122 x 32 dots |
| 3 | Version No. | A type |
| 4 | LCD Color | G=STN/gray Y=STN/yellow-green C=color STN B=STN/blue F=FSTN T=TN |
| 5 | LCD Type | R=positive/reflective P=positive/transflective M=positive/transmissive N=negative/transmissive |
| 6 | Backlight type/color | L=LED array/ yellow-green H=LED edge/white R=LED array/red G=LEDEdge/yellow-green F=RGB D=LED edge/blue E=EL/white B=EL/blue C=CCFL/white Y=LED Bottom/yellow O=LED array/orangr K=LED edge/green |
| 7 | CGRAM Font (applied only on character type) | J=English/Japanese Font E=English/European Font C=English/Cyrillic Font H=English/Hebrew Font |
| 8 | View Angle/ Operating Temperature | B=Bottom/Normal Temperature H=Bottom/Wide Temperature U=Bottom/Ultra wide Temperature T=Top/Normal Temperature W=Top/Wide Temperature C=9H/Normal Temperature |
| 9 | Special Code | 3=3 volt logic power supply n=negative voltage for LCD c=cable/connector xxx=to be assigned on data sheet t=temperature compensation for LCD p=touch panel |

2. Precaution in use of LCD Module

- (1) Avoid applying excessive shocks to the module or making any alterations or modifications to it.
- (2) Don't make extra holes on the printed circuit board, modify its shape or change the components of LCD module.
- (3) Don't disassemble the LCM.
- (4) Don't operate it above the absolute maximum rating.
- (5) Don't drop, bend or twist LCM.
- (6) Soldering: only to the I/O terminals.
- (7) Storage: please storage in anti-static electricity container and clean environment.
- (8) Don't touch the elastmer connector, especially insert a backlight panel (EL or CCFL)

3. General Specification

(1) Mechanical Dimension

| Item | Dimension | Unit |
|-----------------------------------|--|------|
| Number of Characters | 20characters x4 Lines | — |
| Module dimension (L x W x H) | 98.0 x 60.0 x 13.1 (Max)—LED B/L 98.0 x 60.0 x 8.8 (Max)—EL or No B/L | mm |
| View area | 77.0 x 25.2 | mm |
| Active area | 70.4 x 20.8 | mm |
| Dot size | 0.55 x 0.55 | mm |
| Dot pitch | 0.60 x 0.60 | mm |
| Character size (L x W) | 2.95 x 4.75 | mm |
| Character pitch (L x W) | 3.55 x 5.35 | mm |

(2) Controller IC: **ST7066U (or Equivalent) controller**

(3) Temperature Range

| | Normal | Wide |
|-----------|------------|------------|
| Operating | 0 ~+50°C | -20 ~+70°C |
| Storage | -10 ~+60°C | -30 ~+80°C |

4. Absolute Maximum Ratings

4.1 Electrical Absolute Maximum Ratings

(V_{ss}=0V, Ta=25°C)

| Item | Symbol | Min | Max | Unit |
|-----------------------------|----------------------------------|-----------------|-----------------|------|
| Supply Voltage (Logic) | V _{dd} -V _{ss} | -0.3 | 7 | V |
| Supply Voltage (LCD driver) | V _{dd} -V _o | -0.3 | 10 | V |
| Input Voltage | V _I | V _{ss} | V _{dd} | V |
| Normal Type | TOP | 0 | +50 | °C |
| | TSTG | -10 | +60 | °C |
| Wide Temperature Type | Top | -20 | +70 | °C |
| | Tstg | -30 | +80 | °C |

4.2 Environmental Absolute Maximum Ratings

| Item | Operating | | Storage | | Comment |
|-----------|-----------|----------------------|---------|----------------------|----------------------|
| | (Min.) | (Max.) | (Min.) | (Max.) | |
| Humidity | Note(2) | | Note(2) | | Without condensation |
| Vibration | -- | 4.9M/S ² | -- | 19.6M/S ² | XYZ Direction |
| Shock | -- | 29.4M/S ² | -- | 490M/S ² | XYZ Direction |

Note (1) Ta = 0°C : 50Hr Max.

Note (2) Ta ≤ 40°C : 90% RH MAX

Ta > 40°C : Absolute humidity must be lower than the humidity of 90% at 40°C

5. Electrical Characteristics

| Item | Symbol | Condition | Min | Typ | Max | Unit |
|--|----------------------------------|---------------------|----------------------|-----|-----------------|------|
| Supply Voltage For Logic | V _{dd} -V _{ss} | - | 4.5 | - | 5.5 | V |
| Supply Voltage For LCD * Wide Temp、Type | V _{dd} -V _o | * Ta=-20°C | - | 5.0 | - | V |
| | | Ta=0°C | - | - | - | V |
| | | Ta=25°C | - | 4.5 | - | V |
| | | Ta=50°C | - | - | - | V |
| | | * Ta=+70°C | - | 4.0 | - | V |
| Input High Volt. | V _{IH} | - | 0.7* V _{dd} | - | V _{dd} | V |
| Input Low Volt. | V _{IL} | - | -0.3 | - | 0.6 | V |
| Output High Volt. | V _{OH} | - | 3.9 | - | V _{dd} | V |
| Output Low Volt. | V _{OL} | - | - | - | 0.4 | V |
| Supply Current | I _{dd} | V _{dd} =5V | - | 1.2 | - | mA |

6. Optical Characteristics

a. STN

| Item | Symbol | Condition | Min. | Typ. | Max. | Unit |
|--------------------|---------------|-------------|------|------|------|------|
| View Angle | (V) θ | $CR \geq 2$ | 10 | - | 45 | deg |
| | (H) φ | $CR \geq 2$ | -30 | - | 30 | deg |
| Contrast Ratio | CR | - | - | 3 | - | - |
| Response Time 25°C | T rise | - | - | 100 | 150 | ms |
| | T fall | - | - | 150 | 200 | ms |

b. FSTN

| Item | Symbol | Condition | Min. | Typ. | Max. | Unit |
|--------------------|---------------|-------------|------|------|------|------|
| View Angle | (V) θ | $CR \geq 3$ | 10 | - | 60 | deg |
| | (H) φ | $CR \geq 3$ | -45 | - | 45 | deg |
| Contrast Ratio | CR | - | - | 5 | - | - |
| Response Time 25°C | T rise | - | - | 100 | 150 | ms |
| | T fall | - | - | 150 | 200 | ms |

6.1 Definitions

View Angles

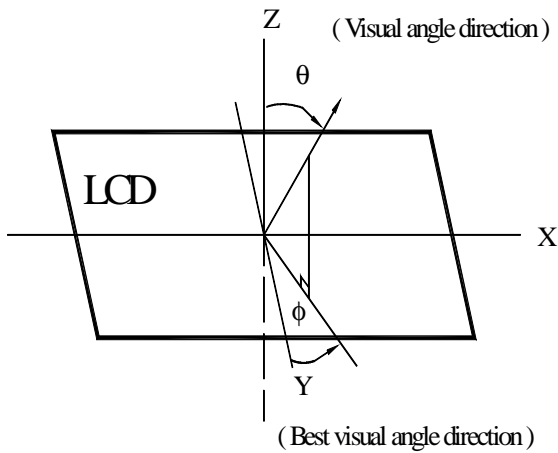

Contrast Ratio

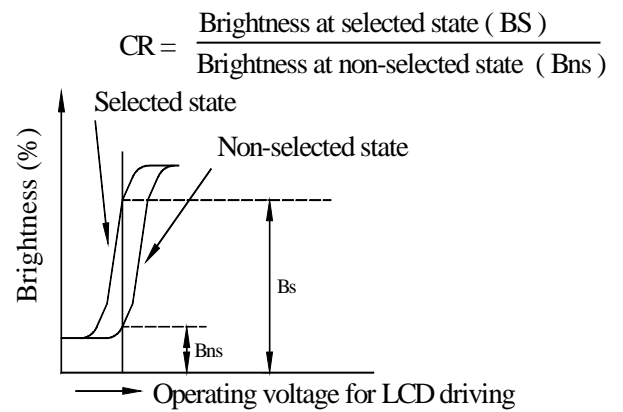

Response Time

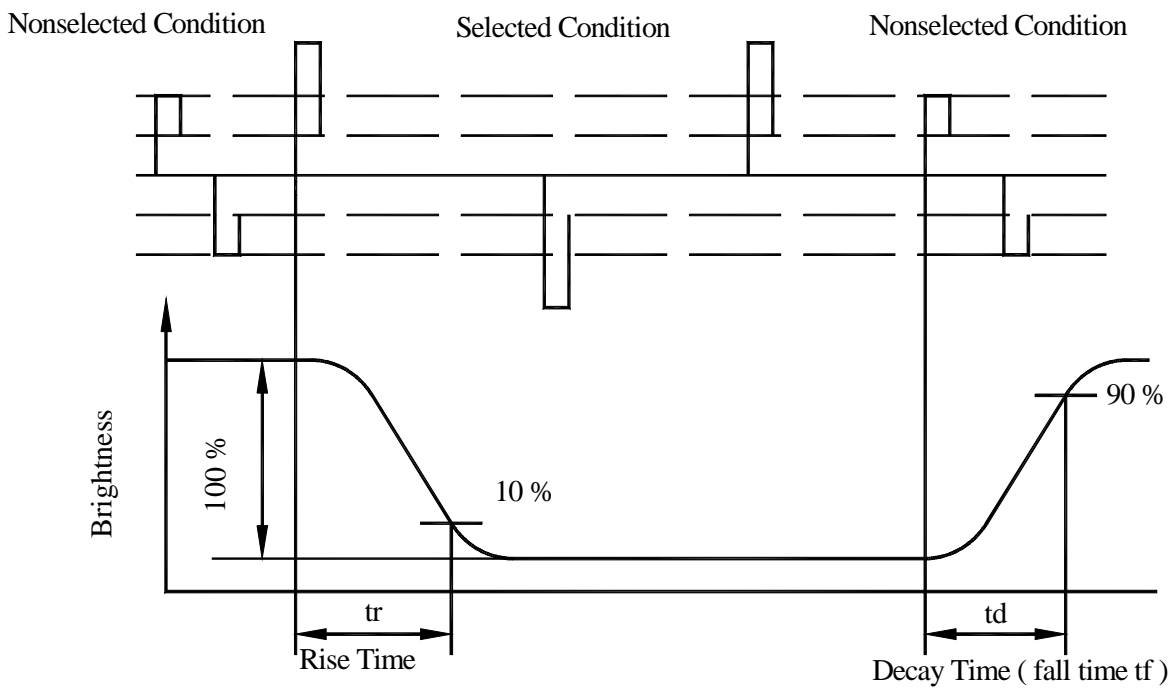

7. Interface Pin Function

| Pin No. | Symbol | Level | Description |
|---------|--------|------------|--|
| 1 | Vss | 0V | Ground |
| 2 | Vdd | 5.0V | Supply Voltage for logic (+3V option) |
| 3 | Vo | (Variable) | Operating voltage for LCD |
| 4 | RS | H/L | H:DATA, L:Instruction code |
| 5 | R/W | H/L | H:Read(MPU→Module)L:Write(MPU→Module) |
| 6 | E | H,H→L | Chip enable signal |
| 7 | DB0 | H/L | Data bit 0 |
| 8 | DB1 | H/L | Data bit 1 |
| 9 | DB2 | H/L | Data bit 2 |
| 10 | DB3 | H/L | Data bit 3 |
| 11 | DB4 | H/L | Data bit 4 |
| 12 | DB5 | H/L | Data bit 5 |
| 13 | DB6 | H/L | Data bit 6 |
| 14 | DB7 | H/L | Data bit 7 |
| 15 | A | - | Power supply for LED backlight (+) |
| 16 | K | - | Power supply for LED backlight (GND) |

8. Power Supply for LCD Module and LCD Operating Voltage a Adjustment

* Standard Type

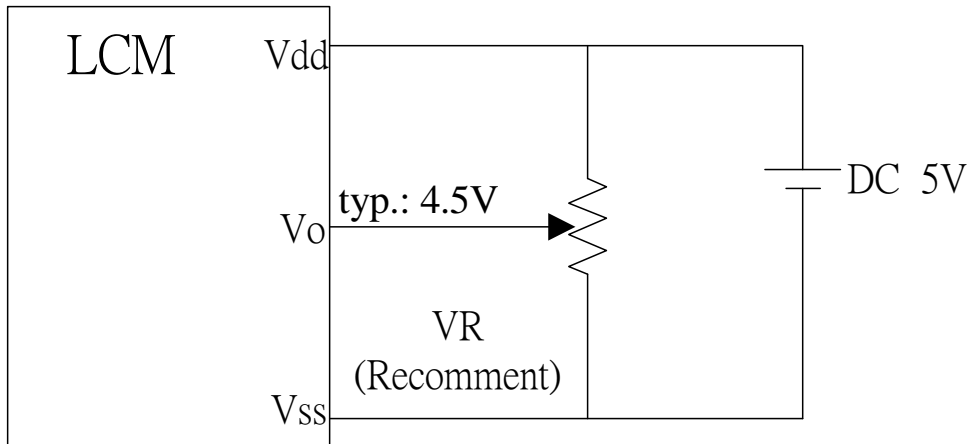

*(Option) LCM operating on " DC 3V " input with external negative voltage

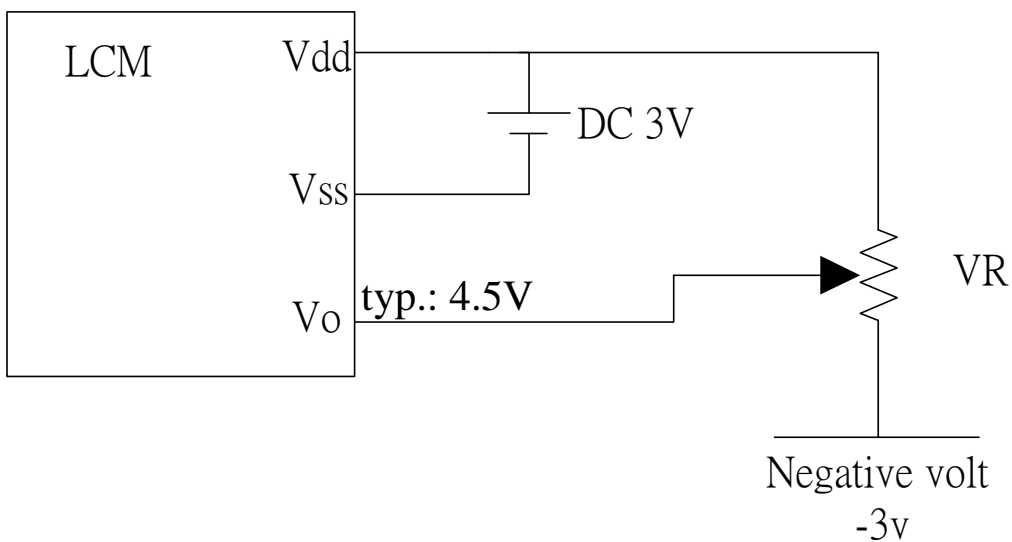

*(Option) LCM operating on " DC 3V " input with built-in negative voltage

LCD Module block diagram

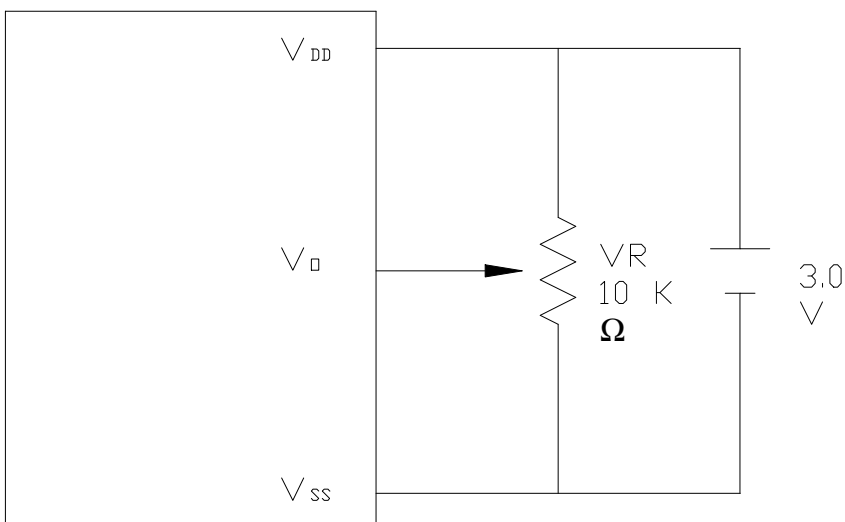

9. Backlight Information

9.1 Specification

(1) LED array / yellow-green

| Parameter | Symbol | Min | Typ | Max | Unit | Test Condition |
|--------------------|------------------|-----|-------|-----|---------------------|---------------------------|
| Supply Current | I _{LED} | - | 280 | - | mA | V=4.2V |
| Supply Voltage | V | - | 4.2 | 4.3 | V | I _{LED} =280mA - |
| Reverse Voltage | V _R | - | - | 8 | V | - |
| Luminous Intensity | I _V | 150 | - | - | cd / m ² | I _{LED} =280mA |
| Wave Length | λ p | - | 574 | - | nm | I _{LED} =280mA |
| Life Time | - | - | 50000 | - | Hr. | I _{LED} ≤ 280mA |
| Color | Yellow Green | | | | | |

(2) LED array / red

| Parameter | Symbol | Min | Typ | Max | Unit | Test Condition |
|--------------------|------------------|-----|-------|-----|---------------------|--------------------------|
| Supply Current | I _{LED} | - | 240 | - | mA | V=3.6V |
| Supply Voltage | V | 3.4 | 3.6 | 3.8 | V | I _{LED} =240mA |
| Reverse Voltage | V _R | - | - | 8 | V | - |
| Luminous Intensity | I _V | 50 | - | - | cd / m ² | I _{LED} =240mA |
| Wave Length | λ p | 640 | 645 | 650 | nm | I _{LED} =240mA |
| Life Time | - | - | 50000 | - | Hr. | I _{LED} ≤ 240mA |
| Color | RED | | | | | |

(3) LED array / Orange

| Parameter | Symbol | Min | Typ | Max | Unit | Test Condition |
|--------------------|------------------|-----|-------|-----|---------------------|--------------------------|
| Supply Current | I _{LED} | - | 180 | - | mA | V=3.9V |
| Supply Voltage | V | 3.7 | 3.9 | 4.1 | V | I _{LED} =180mA |
| Reverse Voltage | V _R | - | - | 8 | V | - |
| Luminous Intensity | I _V | 180 | - | - | cd / m ² | I _{LED} =180mA |
| Wave Length | λ p | 585 | 590 | 595 | nm | I _{LED} =180mA |
| Life Time | - | - | 50000 | - | Hr. | I _{LED} ≤ 180mA |
| Color | Orange | | | | | |

(4) LED edge / white

| Parameter | Symbol | Min | Typ | Max | Unit | Test Condition |
|--------------------|------------------|-----|-------|-----|-------------------|--------------------------|
| Supply Current | I _{LED} | - | 60 | - | mA | V= 3.4V |
| Supply Voltage | V | - | 3.2 | 3.4 | V | I _{LED} =60 mA |
| Reverse Voltage | V _R | - | - | 8 | V | - |
| Luminous Intensity | I _V | 200 | - | - | cd/m ² | I _{LED} =60 mA |
| Life Time | - | - | 20000 | - | Hr. | I _{LED} ≤ 60 mA |
| Color | white | | | | | |

(5) LED edge / Green

| Parameter | Symbol | Min | Typ | Max | Unit | Test Condition |
|--------------------|------------------|-----|-------|-----|-------------------|--------------------------|
| Supply Current | I _{LED} | - | 60 | - | mA | V= 3.2V |
| Supply Voltage | V | - | 3.2 | 3.6 | V | I _{LED} =60 mA |
| Reverse Voltage | V _R | - | - | 5 | V | - |
| Luminous Intensity | I _V | 180 | 220 | - | cd/m ² | I _{LED} =60 mA |
| Wave Length | λ _p | 520 | - | 530 | nm | I _{LED} =60mA |
| Life Time | - | - | 20000 | - | Hr. | I _{LED} ≤ 60 mA |
| Color | Green | | | | | |

(6) EL white / blue

| Parameter | Symbol | Min | Typ | Max | Unit | Test Condition |
|-------------------|--------------|-----|----------------|------|-------------------|------------------------|
| Drive Voltage | Vmax | - | 110 | 170 | Vrms | 25°C |
| Drive Wave | Fmax | - | 400 | 1000 | Hz | 25°C |
| Brightness | - | - | - | - | cd/m ² | 110V/400Hz |
| Power Consumption | - | - | 48.3 | - | mW | 110V/400Hz |
| Chromatism | X | - | 0.3019 (white) | - | - | 110V/400Hz |
| | | | 0.330 (blue) | | | |
| | Y | - | 0.3929 (white) | - | - | 110V/400Hz |
| | | | 0.365 (blue) | | | |
| Life time | 5000 | | | | hour | 110V/400Hz |
| Color | White / Blue | | | | - | Light on 110V/400Hz |

9.2 Backlight driving methods

a. LED B/L drive from pin15 (LED+) pin16 (LED-)

a.1 array / yellow-green

LCM

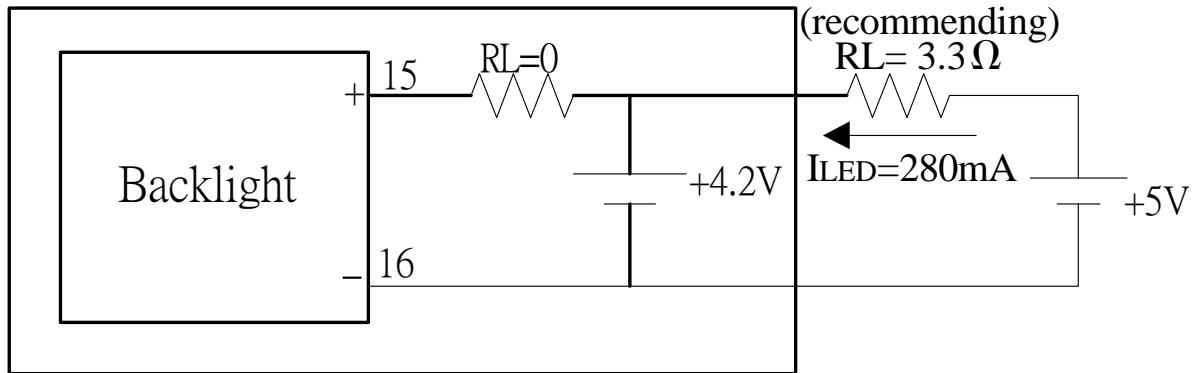

a.2 edge / white

LCM

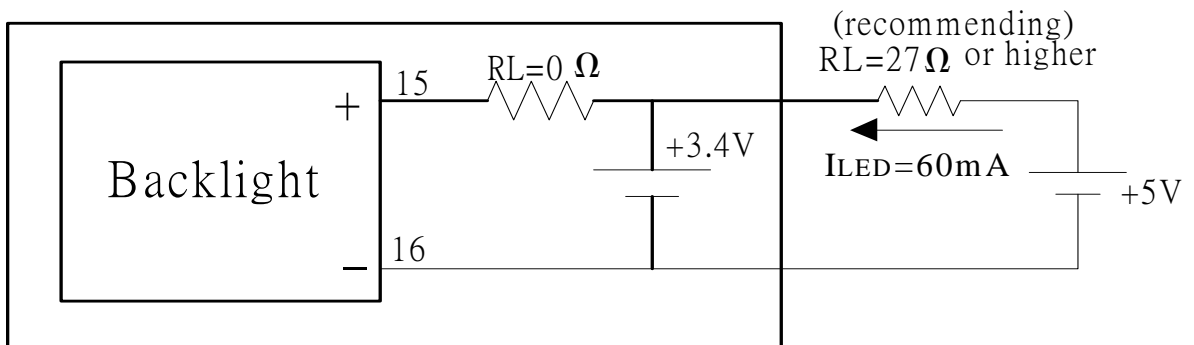

a.3 array / RED

LCM

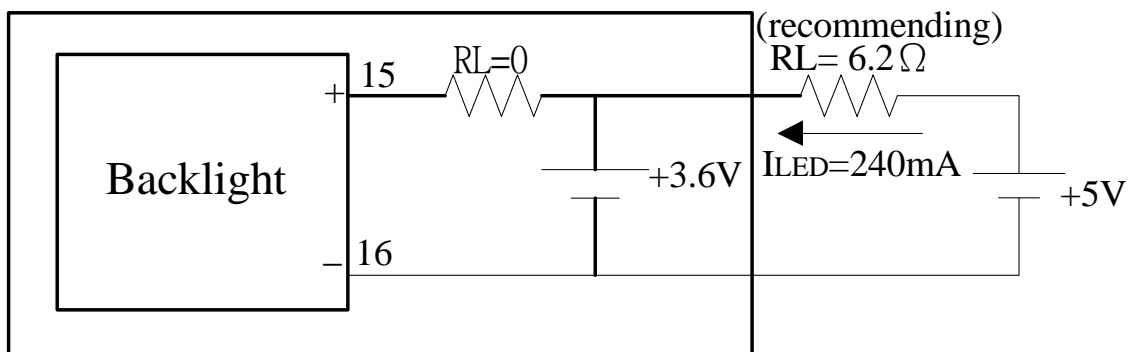

a.4 array / Orange

LCM

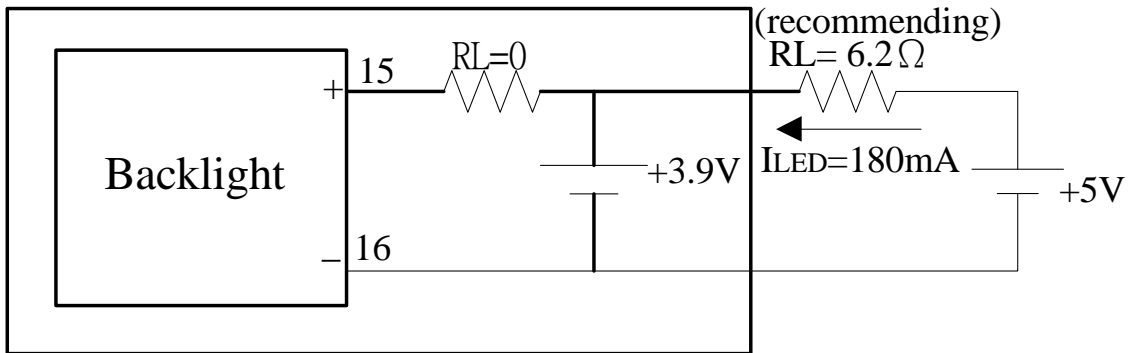

a.5 edge / green

LCM

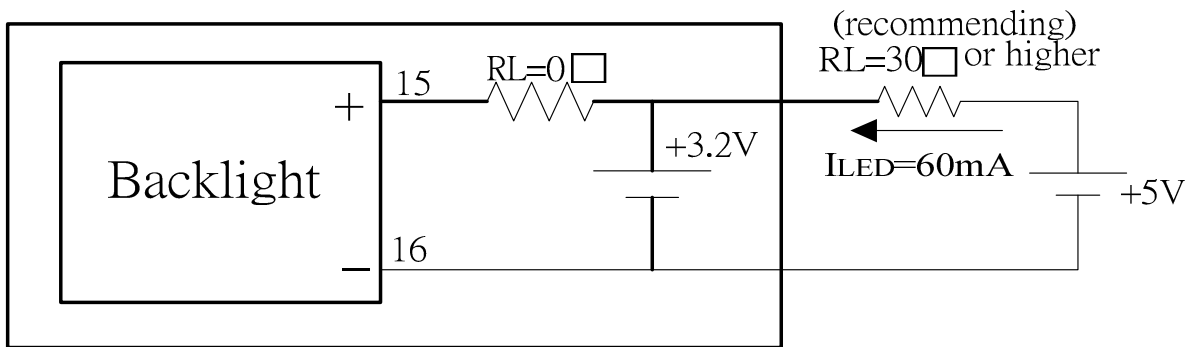

b. LED B/L drive from A.K directly

b.1 array / yellow-green

LCM

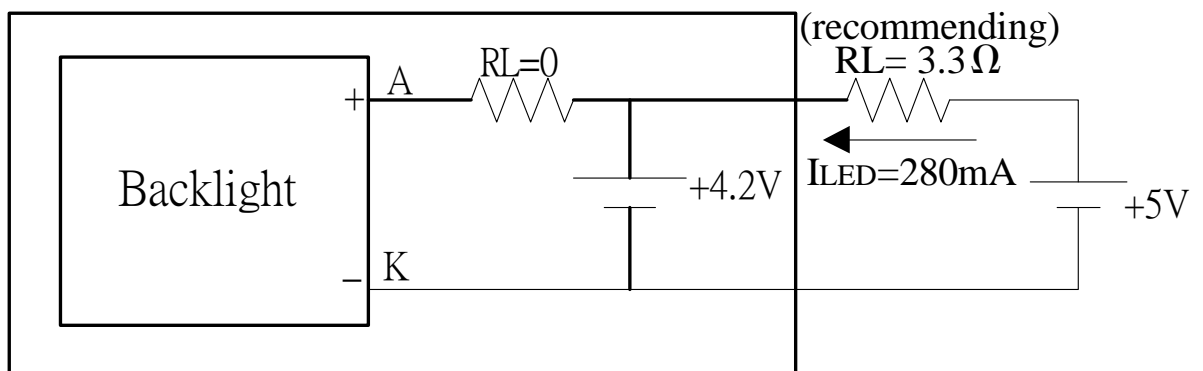

b.2 edge / white

LCM

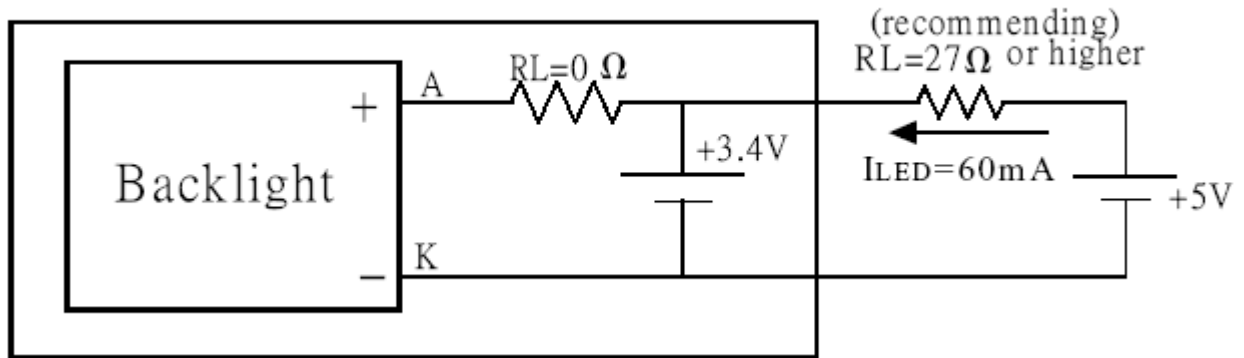

b.3 array / red

LCM

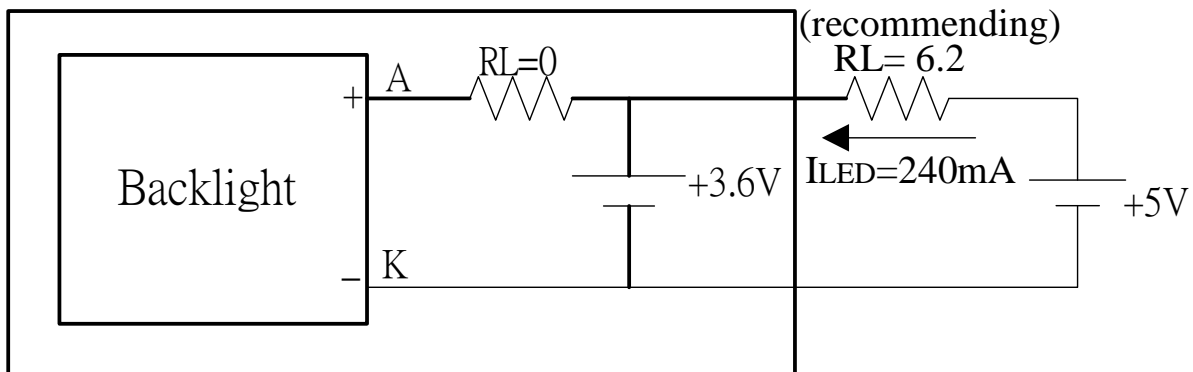

b.4 array / Orange

LCM

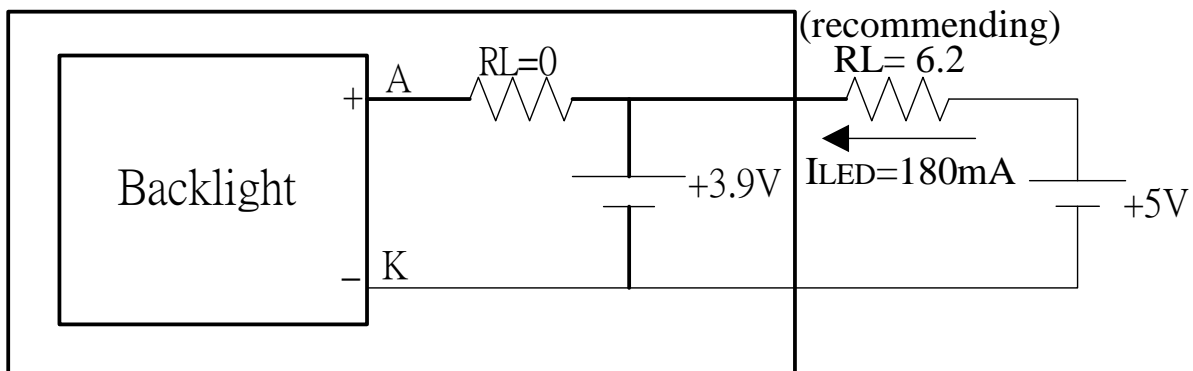

b.2 edge / green

LCM

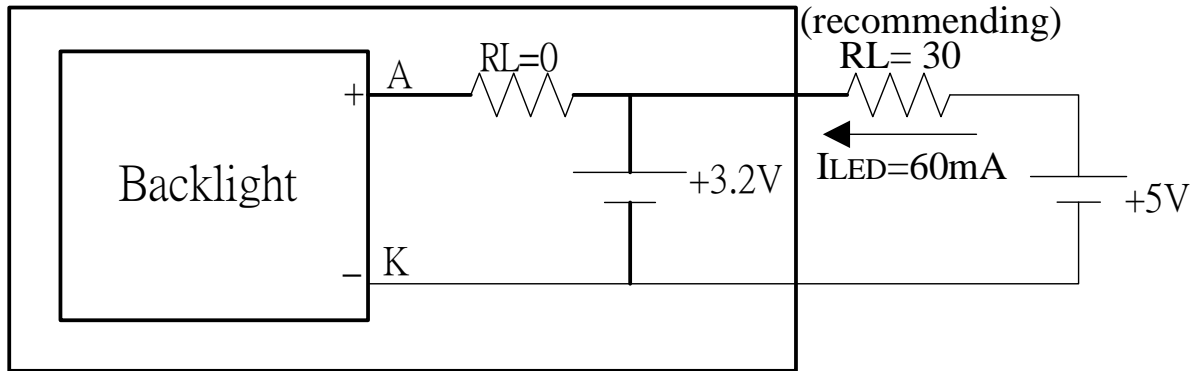

c. * (Option) LED B/L drive from pin1 (Vss) pin2 (Vdd)

LCM

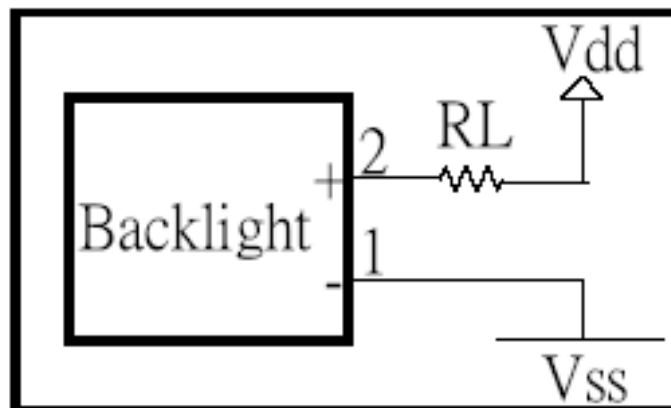

- (1) Jump 1,2 Short
- (2) Current Resistor required on RL
- (3) Jump 15,16 open
- (4) To be sure of enough current supply for both Vdd + LED B/L

d. EL B/L drive from A.K directly

LCM

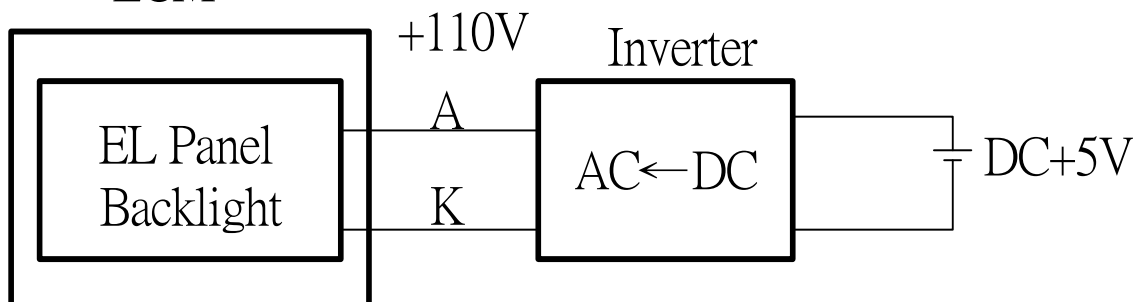

10. Quality Assurance

10.1 Inspection conditions

The LCD shall be inspected under 40W white fluorescent light.

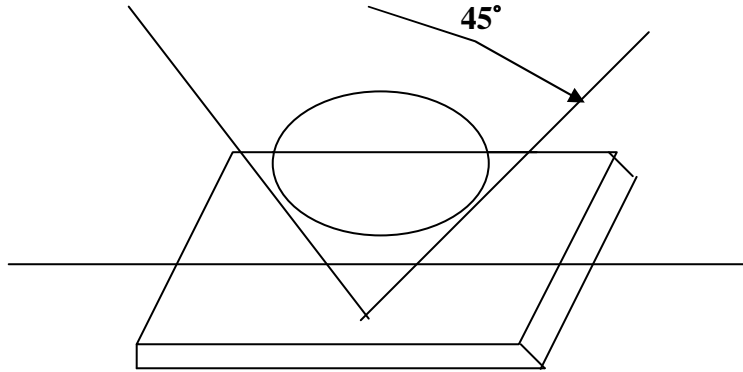

Definition of applicable Zones

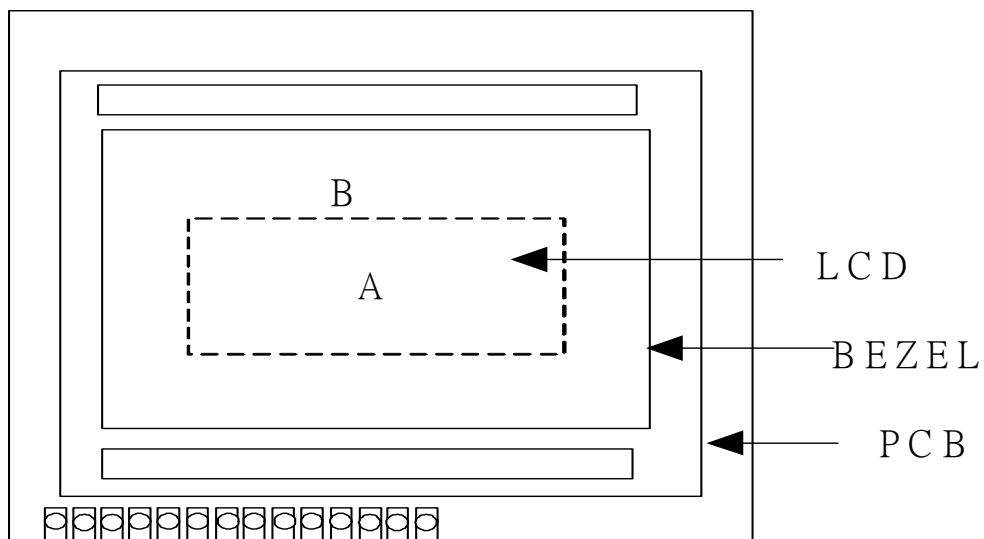

A : Display Area

B : Non-Display Area

10.2 Inspection Parameters

| NO. | Parameter | Criteria | | | | | | | | | | | | | | | | | | | | | | | | | | |
|------------------------|---|---|---------------------|-------------------|-------------------|------------------|------------------|------------------|---|--------------|---|---------------|-------|-----|------------------------|-----|--------------|------------------------|---|---|--------------|---------------|---|---|---|-----------|---|---|
| 1 | Black or White spots | <table border="1"> <thead> <tr> <th rowspan="2">Zone Dimension</th> <th colspan="2">Acceptable Number</th> <th rowspan="2">Class Of Defects</th> <th rowspan="2">Acceptable Level</th> </tr> <tr> <th>A</th> <th>B</th> </tr> </thead> <tbody> <tr> <td>$D < 0.15$</td> <td>*</td> <td>*</td> <td rowspan="4">Minor</td> <td rowspan="4">2.5</td> </tr> <tr> <td>$0.15 \leq D \leq 0.2$</td> <td>4</td> <td>4</td> </tr> <tr> <td>$0.2 \leq D \leq 0.25$</td> <td>2</td> <td>2</td> </tr> <tr> <td>$D \leq 0.3$</td> <td>0</td> <td>1</td> </tr> </tbody> </table> <p>$D = (\text{Long} + \text{Short})/2$ *: Disregard</p> | Zone Dimension | Acceptable Number | | Class Of Defects | Acceptable Level | A | B | $D < 0.15$ | * | * | Minor | 2.5 | $0.15 \leq D \leq 0.2$ | 4 | 4 | $0.2 \leq D \leq 0.25$ | 2 | 2 | $D \leq 0.3$ | 0 | 1 | | | | | |
| Zone Dimension | Acceptable Number | | | Class Of Defects | Acceptable Level | | | | | | | | | | | | | | | | | | | | | | | |
| | A | B | | | | | | | | | | | | | | | | | | | | | | | | | | |
| $D < 0.15$ | * | * | Minor | 2.5 | | | | | | | | | | | | | | | | | | | | | | | | |
| $0.15 \leq D \leq 0.2$ | 4 | 4 | | | | | | | | | | | | | | | | | | | | | | | | | | |
| $0.2 \leq D \leq 0.25$ | 2 | 2 | | | | | | | | | | | | | | | | | | | | | | | | | | |
| $D \leq 0.3$ | 0 | 1 | | | | | | | | | | | | | | | | | | | | | | | | | | |
| 2 | Scratch, Substances | <table border="1"> <thead> <tr> <th colspan="2" rowspan="2">Zone X(mm) Y(mm)</th> <th colspan="2">Acceptable Number</th> <th rowspan="2">Class Of Defects</th> <th rowspan="2">Acceptable Level</th> </tr> <tr> <th>A</th> <th>B</th> </tr> </thead> <tbody> <tr> <td>*</td> <td>$0.04 \geq W$</td> <td>*</td> <td>*</td> <td rowspan="4">Minor</td> <td rowspan="4">2.5</td> </tr> <tr> <td>$3.0 \geq L$</td> <td>$0.06 \geq W$</td> <td>4</td> <td>4</td> </tr> <tr> <td>$2.0 \geq L$</td> <td>$0.08 \geq W$</td> <td>2</td> <td>3</td> </tr> <tr> <td>—</td> <td>$0.1 < W$</td> <td>0</td> <td>1</td> </tr> </tbody> </table> <p>X: Length Y: Width *: Disregard Total defects should not exceed 4/module</p> | Zone X(mm) Y(mm) | | Acceptable Number | | Class Of Defects | Acceptable Level | A | B | * | $0.04 \geq W$ | * | * | Minor | 2.5 | $3.0 \geq L$ | $0.06 \geq W$ | 4 | 4 | $2.0 \geq L$ | $0.08 \geq W$ | 2 | 3 | — | $0.1 < W$ | 0 | 1 |
| Zone X(mm) Y(mm) | | Acceptable Number | | | Class Of Defects | Acceptable Level | | | | | | | | | | | | | | | | | | | | | | |
| | | A | B | | | | | | | | | | | | | | | | | | | | | | | | | |
| * | $0.04 \geq W$ | * | * | Minor | 2.5 | | | | | | | | | | | | | | | | | | | | | | | |
| $3.0 \geq L$ | $0.06 \geq W$ | 4 | 4 | | | | | | | | | | | | | | | | | | | | | | | | | |
| $2.0 \geq L$ | $0.08 \geq W$ | 2 | 3 | | | | | | | | | | | | | | | | | | | | | | | | | |
| — | $0.1 < W$ | 0 | 1 | | | | | | | | | | | | | | | | | | | | | | | | | |
| 3 | Air Bubbles (between glass & polarizer) | <table border="1"> <thead> <tr> <th rowspan="2">Zone Dimension</th> <th colspan="2">Acceptable Number</th> <th rowspan="2">Class Of Defects</th> <th rowspan="2">Acceptable Level</th> </tr> <tr> <th>A</th> <th>B</th> </tr> </thead> <tbody> <tr> <td>$D \leq 0.2$</td> <td>*</td> <td>*</td> <td rowspan="3">Minor</td> <td rowspan="3">2.5</td> </tr> <tr> <td>$0.2 < D \leq 0.5$</td> <td>2</td> <td>*</td> </tr> <tr> <td>$0.5 < D$</td> <td>0</td> <td>1</td> </tr> </tbody> </table> <p>*: Disregard Total defects shall not exceed 3/module.</p> | Zone Dimension | Acceptable Number | | Class Of Defects | Acceptable Level | A | B | $D \leq 0.2$ | * | * | Minor | 2.5 | $0.2 < D \leq 0.5$ | 2 | * | $0.5 < D$ | 0 | 1 | | | | | | | | |
| Zone Dimension | Acceptable Number | | | Class Of Defects | Acceptable Level | | | | | | | | | | | | | | | | | | | | | | | |
| | A | B | | | | | | | | | | | | | | | | | | | | | | | | | | |
| $D \leq 0.2$ | * | * | Minor | 2.5 | | | | | | | | | | | | | | | | | | | | | | | | |
| $0.2 < D \leq 0.5$ | 2 | * | | | | | | | | | | | | | | | | | | | | | | | | | | |
| $0.5 < D$ | 0 | 1 | | | | | | | | | | | | | | | | | | | | | | | | | | |

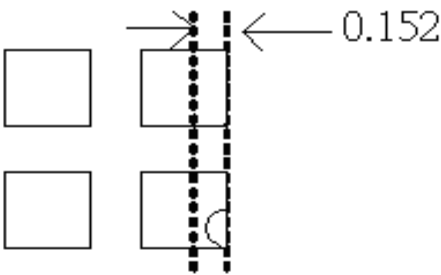
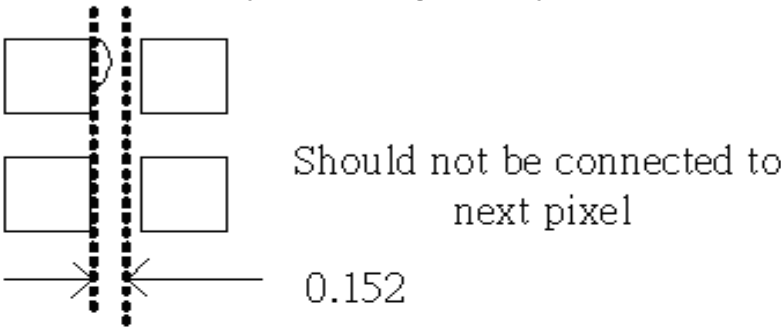
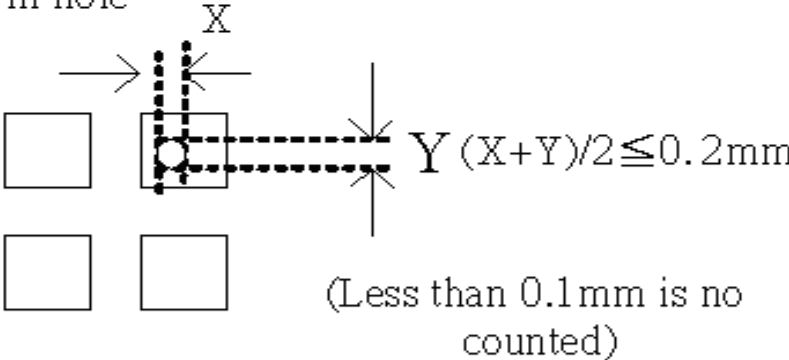
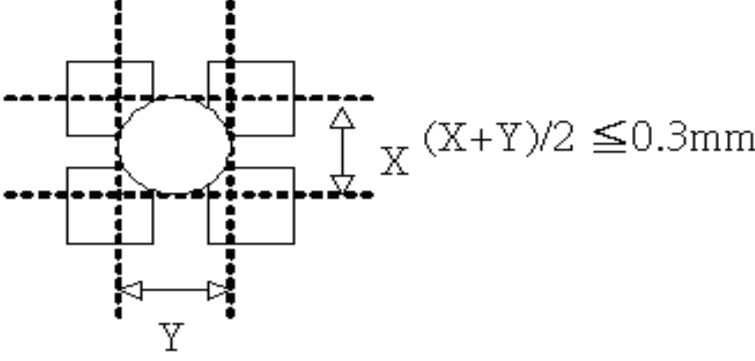
| | | |
|----------|-------------------|---|
| <p>4</p> | <p>Uniformity</p> | <p>(1) Pixel shape (with Dent)</p>  <p>(2) Pixel shape (With Projection)</p>  <p>(3) Pin hole</p>  <p>(4) Deformation</p>  <p>Total acceptable number : 1/pixel,5/cell</p> |
|----------|-------------------|---|

11. Reliability

■ Content of Reliability Test

| Environmental Test | | | | |
|--------------------|----------------------------|--|---|---------------------|
| No. | Test Item | Content of Test | Test Condition | Applicable Standard |
| 1 | High Temperature storage | Endurance test applying the high storage temperature for a long time. | 80°C 96hrs | — |
| 2 | Low Temperature storage | Endurance test applying the high storage temperature for a long time. | -30°C 96hrs | — |
| 3 | High Temperature Operation | Endurance test applying the electric stress (Voltage & Current) and the thermal stress to the element for a long time. | 70°C 96hrs | — |
| 4 | Low Temperature Operation | Endurance test applying the electric stress under low temperature for a long time. | -20°C 96hrs | — |
| 5 | Humidity Test | Endurance test applying the high humidity storage for a long time. | 40°C, 90% RH 96hrs | — |
| 6 | Thermal Shock Test | Endurance test applying the low and high temperature cycle. -30°C 25°C 80°C ←—————→ 30min 5min 30min 1 cycle | -30°C / 80°C 5 cycles | — |
| 7 | Vibration test | Endurance test applying the vibration during transportation and using. | Total Fixed Amplitude: 1.5mm Vibration Frequency : 10~55Hz One cycle 60 seconds to 3 direction of X, Y, Z for each 15minutes | — |

***Supply voltage for logic system=5V. Supply voltage for LCD system =Operating voltage at 25°C

12. Appendix (Drawing , ST7066U controller data)

12-1 Drawing

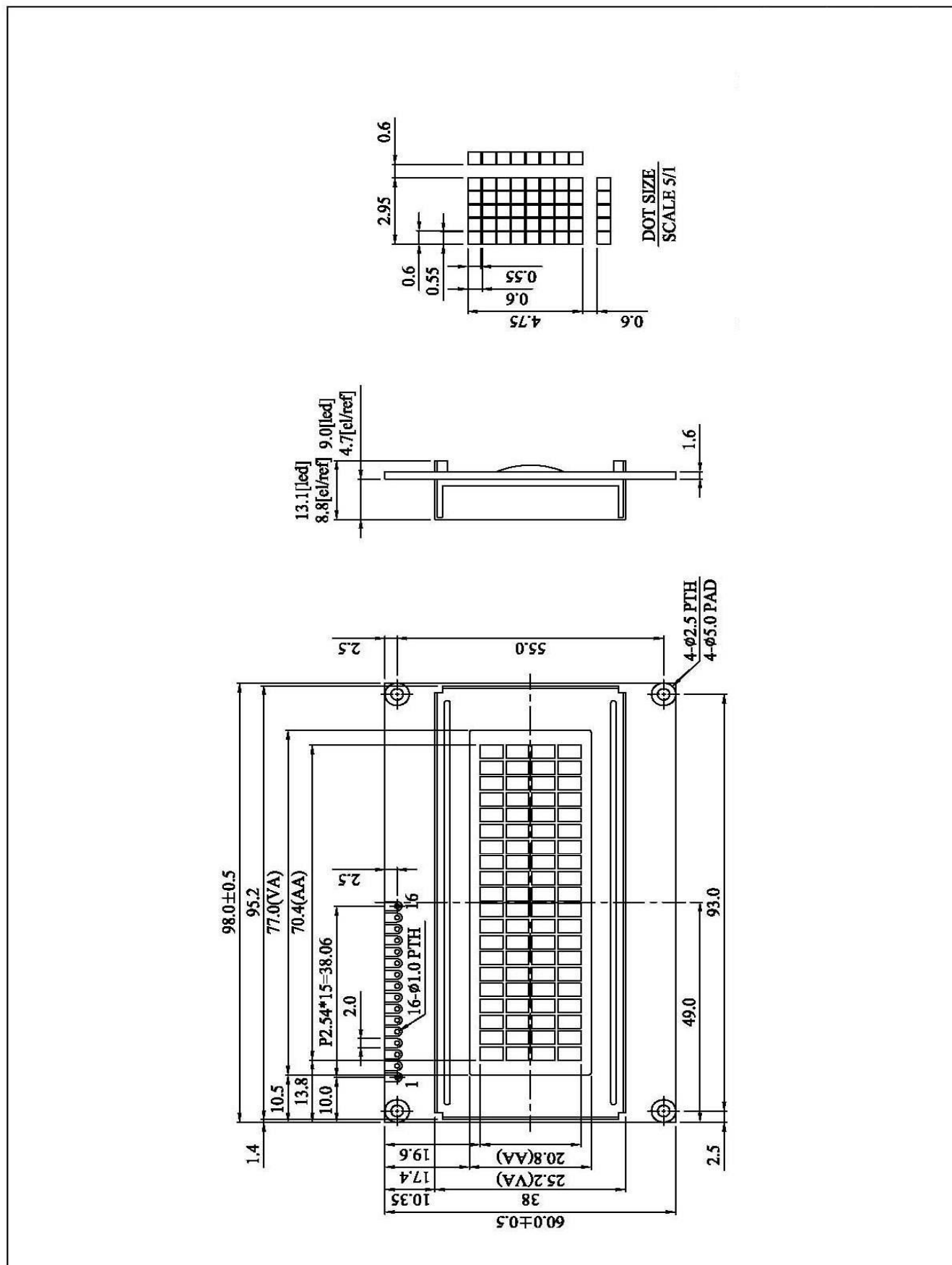

12-2. ST7066U controller data

12-2.1 Function description

The LCD display Module is built in a LSI controller, the controller has two 8-bit registers, an instruction register (IR) and a data register (DR).

The IR stores instruction codes, such as display clear and cursor shift, and address information for display data RAM (DDRAM) and character generator (CGRAM). The IR can only be written from the MPU. The DR temporarily stores data to be written or read from DDRAM or CGRAM. When address information is written into the IR, then data is stored into the DR from DDRAM or CGRAM. By the register selector (RS) signal, these two registers can be selected.

| RS | R/W | Operation |
|----|-----|---|
| 0 | 0 | IR write as an internal operation (display clear, etc.) |
| 0 | 1 | Read busy flag (DB7) and address counter (DB0 to DB7) |
| 1 | 0 | Write data to DDRAM or CGRAM (DR to DDRAM or CGRAM) |
| 1 | 1 | Read data from DDRAM or CGRAM (DDRAM or CGRAM to DR) |

Busy Flag (BF)

When the busy flag is 1, the controller LSI is in the internal operation mode, and the next instruction will not be accepted. When RS=0 and R/W=1, the busy flag is output to DB7. The next instruction must be written after ensuring that the busy flag is 0.

Address Counter (AC)

The address counter (AC) assigns addresses to both DDRAM and CGRAM

Display Data RAM (DDRAM)

This DDRAM is used to store the display data represented in 8-bit character codes. Its extended capacity is 80x8 bits or 80 characters. Below figure is the relationship between DDRAM addresses and positions on the liquid crystal display.

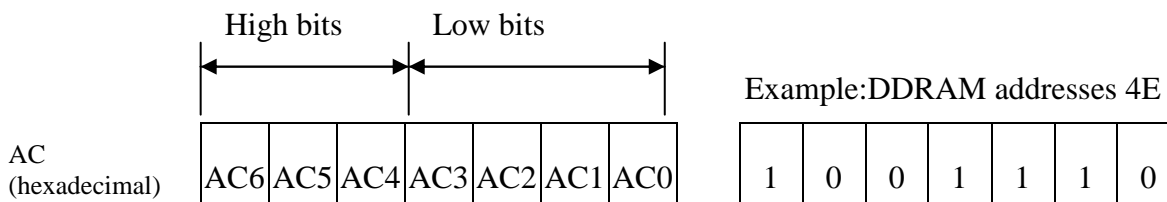

DDRAM Address

Display position DDRAM address

1 2 3 4 5 6 7 8 9 10 11 12 13 14 15 16 17 18 19 20

| | | | | | | | | | | | | | | | | | | | |
|----|----|----|----|----|----|----|----|----|----|----|----|----|----|----|----|----|----|----|----|
| 00 | 01 | 02 | 03 | 04 | 05 | 06 | 07 | 08 | 09 | 0A | 0B | 0C | 0D | 0E | 0F | 10 | 11 | 12 | 13 |
| 40 | 41 | 42 | 43 | 44 | 45 | 46 | 47 | 48 | 49 | 4A | 4B | 4C | 4D | 4E | 4F | 50 | 51 | 52 | 53 |
| 14 | 15 | 16 | 17 | 18 | 19 | 1A | 1B | 1C | 1D | 1E | 1F | 20 | 21 | 22 | 23 | 24 | 25 | 26 | 27 |
| 54 | 55 | 56 | 57 | 58 | 59 | 5A | 5B | 5C | 5D | 5E | 5F | 60 | 61 | 62 | 63 | 64 | 65 | 66 | 67 |

Example: 4-Line by 20-Character Display

Character Generator ROM (CGROM)

The CGROM generate 5×8 dot or 5×10 dot character patterns from 8-bit character codes. See Table 2.

Character Generator RAM (CGRAM)

In CGRAM, the user can rewrite character by program. For 5×8 dots, eight character patterns can be written, and for 5×10 dots, four character patterns can be written.

Write into DDRAM the character code at the addresses shown as the left column of table 1. To show the character patterns stored in CGRAM.

Relationship between CGRAM Addresses, Character Codes (DDRAM) and Character Patterns (CGRAM Data)

For 5 * 8 dot character patterns

| Character Codes (DDRAM data) | | CGRAM Address | | Character Patterns (CGRAM data) | | |
|--------------------------------|-------|---------------|-------|-----------------------------------|-----------|------------------------|
| 7 6 5 4 3 2 1 0 | | 5 4 3 2 1 0 | | 7 6 5 4 3 2 1 0 | | |
| High | Low | High | Low | High | Low | |
| 0 0 0 0 * 0 0 0 | | 0 0 0 | 0 0 0 | * * * | 0 | Character pattern(1) |
| | | | 0 0 1 | * * * | 0 0 0 | |
| | | | 0 1 0 | * * * | 0 0 0 | |
| | | | 0 1 1 | * * * | 0 | |
| | | | 1 0 0 | * * * | 0 0 0 | |
| | | | 1 0 1 | * * * | 0 0 0 | |
| | | | 1 1 0 | * * * | 0 0 0 | |
| | | | 1 1 1 | * * * | 0 0 0 0 0 | |
| | | | 0 0 0 | * * * | 0 0 0 0 | |
| | | | 0 0 1 | * * * | 0 0 0 0 | |
| 0 0 0 0 * 0 0 1 | | 0 0 1 | 0 1 0 | * * * | 0 | Character pattern(2) |
| | | | 0 1 1 | * * * | 0 0 0 0 | |
| | | | 1 0 0 | * * * | 0 0 0 0 | |
| | | | 1 0 1 | * * * | 0 0 0 0 | |
| | | | 1 1 0 | * * * | 0 0 0 0 | |
| 1 1 1 | * * * | 0 0 0 0 | | | | |
| | | | 0 0 0 | * * * | | Cursor pattern |
| | | | 0 0 1 | * * * | | |
| 0 0 0 0 * 1 1 1 | | 1 1 1 | 1 0 0 | | | |
| | | | 1 0 1 | | | |
| | | | 1 1 0 | | | |
| | | | 1 1 1 | | | |
| | | | | * * * | | |

For 5 * 10 dot character patterns

| Character Codes (DDRAM data) | | CGRAM Address | | Character Patterns (CGRAM data) | | |
|--------------------------------|-------|---------------|---------|-----------------------------------|-----------|-------------------|
| 7 6 5 4 3 2 1 0 | | 5 4 3 2 1 0 | | 7 6 5 4 3 2 1 0 | | |
| High | Low | High | Low | High | Low | |
| 0 0 0 0 * 0 0 0 | | 0 0 | 0 0 0 0 | * * * | 0 0 0 0 0 | Character pattern |
| | | | 0 0 0 1 | * * * | 0 0 0 0 0 | |
| | | | 0 0 1 0 | * * * | 0 0 0 0 | |
| | | | 0 0 1 1 | * * * | 0 0 | |
| | | | 0 1 0 0 | * * * | 0 0 0 | |
| | | | 0 1 0 1 | * * * | 0 0 0 | |
| | | | 0 1 1 0 | * * * | 0 | |
| | | | 0 1 1 1 | * * * | 0 0 0 0 | |
| | | | 1 0 0 0 | * * * | 0 0 0 0 | |
| | | | 1 0 0 1 | * * * | 0 0 0 0 | |
| 1 0 1 0 | * * * | 0 0 0 0 | | | | |
| | | | | * * * | | Cursor pattern |
| | | | | * * * | | |
| | | | 1 1 1 1 | * * * | * * * * * | |

■ : " High "

12-2.2 C.G ROM table. table 2

Code J: English – Japanese Font

| Upper 4 bit Lower 4 bit | LLLL | LLLH | LLHL | LLHH | LHLL | LHLH | LHHL | LHHH | HLLL | HLLH | HLHL | HLHH | HHLL | HHLH | HHHL | HHHH |
|----------------------------------|------------------|------|------|------|------|------|------|------|------|------|------|------|------|------|------|------|
| LLLL | CG RAM (1) | | | G | A | P | \ | F | | | | | 一 | ア | イ | ウ |
| LLLH | (2) | | ! | L | A | B | a | a | | | h | フ | ク | ク | ク | ク |
| LLHL | (3) | | " | Z | B | R | B | r | | | f | フ | ク | ク | ク | ク |
| LLHH | (4) | | # | C | S | C | s | | | | j | フ | ク | ク | ク | ク |
| LHLL | (5) | | \$ | A | D | T | t | | | | v | フ | ク | ク | ク | ク |
| LHLH | (6) | | % | B | E | L | l | l | | | . | フ | ク | ク | ク | ク |
| LHHL | (7) | | & | S | F | V | v | | | | w | フ | ク | ク | ク | ク |
| LHHH | (8) | | ' | Z | B | L | l | l | | | . | フ | ク | ク | ク | ク |
| HLLL | (1) | | (| C | H | N | N | | | | s | フ | ク | ク | ク | ク |
| HLLH | (2) | |) | S | T | V | v | | | | w | フ | ク | ク | ク | ク |
| HLHL | (3) | | * | # | J | Z | z | | | | x | フ | ク | ク | ク | ク |
| HLHH | (4) | | + | # | K | L | l | l | | | . | フ | ク | ク | ク | ク |
| HHLL | (5) | | , | < | L | F | I | I | | | . | フ | ク | ク | ク | ク |
| HHLH | (6) | | - | = | M | J | m | l | | | . | フ | ク | ク | ク | ク |
| HHHL | (7) | | . | > | N | M | m | l | | | . | フ | ク | ク | ク | ク |
| HHHH | (8) | | / | > | O | L | o | e | | | . | フ | ク | ク | ク | ク |

Code E: English - European Font

| Upper 1 bit Lower 4 bit | LLLL | LLLH | LLHL | LLHH | LHLL | LHLH | LHHL | LHHH | HLLL | HLLH | HLHL | HLHH | HHLL | HHLH | HHHL | HHHH |
|----------------------------------|------------------|------|------|------|------|------|------|------|------|------|------|------|------|------|------|------|
| LLLL | CG RAM (1) | ! | 2 | 3 | 4 | 5 | 6 | 7 | 8 | 9 | 0 | 1 | 2 | 3 | 4 | 5 |
| LLLH | CG RAM (2) | ! | 2 | 3 | 4 | 5 | 6 | 7 | 8 | 9 | 0 | 1 | 2 | 3 | 4 | 5 |
| LLHL | CG RAM (3) | ! | 2 | 3 | 4 | 5 | 6 | 7 | 8 | 9 | 0 | 1 | 2 | 3 | 4 | 5 |
| LLHH | CG RAM (4) | ! | 2 | 3 | 4 | 5 | 6 | 7 | 8 | 9 | 0 | 1 | 2 | 3 | 4 | 5 |
| LHLL | CG RAM (5) | ! | 2 | 3 | 4 | 5 | 6 | 7 | 8 | 9 | 0 | 1 | 2 | 3 | 4 | 5 |
| LHLH | CG RAM (6) | ! | 2 | 3 | 4 | 5 | 6 | 7 | 8 | 9 | 0 | 1 | 2 | 3 | 4 | 5 |
| LHHL | CG RAM (7) | ! | 2 | 3 | 4 | 5 | 6 | 7 | 8 | 9 | 0 | 1 | 2 | 3 | 4 | 5 |
| LHHH | CG RAM (8) | ! | 2 | 3 | 4 | 5 | 6 | 7 | 8 | 9 | 0 | 1 | 2 | 3 | 4 | 5 |
| HLLL | CG RAM (1) | ! | 2 | 3 | 4 | 5 | 6 | 7 | 8 | 9 | 0 | 1 | 2 | 3 | 4 | 5 |
| HLLH | CG RAM (2) | ! | 2 | 3 | 4 | 5 | 6 | 7 | 8 | 9 | 0 | 1 | 2 | 3 | 4 | 5 |
| HLHL | CG RAM (3) | ! | 2 | 3 | 4 | 5 | 6 | 7 | 8 | 9 | 0 | 1 | 2 | 3 | 4 | 5 |
| HLHH | CG RAM (4) | ! | 2 | 3 | 4 | 5 | 6 | 7 | 8 | 9 | 0 | 1 | 2 | 3 | 4 | 5 |
| HHLL | CG RAM (5) | ! | 2 | 3 | 4 | 5 | 6 | 7 | 8 | 9 | 0 | 1 | 2 | 3 | 4 | 5 |
| HHLH | CG RAM (6) | ! | 2 | 3 | 4 | 5 | 6 | 7 | 8 | 9 | 0 | 1 | 2 | 3 | 4 | 5 |
| HHHL | CG RAM (7) | ! | 2 | 3 | 4 | 5 | 6 | 7 | 8 | 9 | 0 | 1 | 2 | 3 | 4 | 5 |
| HHHH | CG RAM (8) | ! | 2 | 3 | 4 | 5 | 6 | 7 | 8 | 9 | 0 | 1 | 2 | 3 | 4 | 5 |

Code C: English - Cyrillic Font

| Upper 4 bit Lower 4 bit | LLLL | LLLH | LLHL | LLHH | LHLL | LHLH | LHHL | LHHH | HLLL | HLLH | HLHL | HLHH | HHLL | HHLH | HHHL | HHHH |
|----------------------------------|------------------|------|------|------|------|------|------|------|------|------|------|------|------|------|------|------|
| LLLL | CG RAM (1) | | | 0 | 1 | 2 | 3 | 4 | | | 5 | 6 | 7 | 8 | 9 | 0 |
| LLLH | CG RAM (2) | | ! | 1 | 2 | 3 | 4 | 5 | | | 6 | 7 | 8 | 9 | 0 | 1 |
| LLHL | CG RAM (3) | | " | 2 | 3 | 4 | 5 | 6 | | | 7 | 8 | 9 | 0 | 1 | 2 |
| LLHH | CG RAM (4) | | # | 3 | 4 | 5 | 6 | 7 | | | 8 | 9 | 0 | 1 | 2 | 3 |
| LHLL | CG RAM (5) | | \$ | 4 | 5 | 6 | 7 | 8 | | | 9 | 0 | 1 | 2 | 3 | 4 |
| LHLH | CG RAM (6) | | % | 5 | 6 | 7 | 8 | 9 | | | 0 | 1 | 2 | 3 | 4 | 5 |
| LHHL | CG RAM (7) | | & | 6 | 7 | 8 | 9 | 0 | | | 1 | 2 | 3 | 4 | 5 | 6 |
| LHHH | CG RAM (8) | | ' | 7 | 8 | 9 | 0 | 1 | | | 2 | 3 | 4 | 5 | 6 | 7 |
| HLLL | CG RAM (1) | | (| 8 | 9 | 0 | 1 | 2 | | | 3 | 4 | 5 | 6 | 7 | 8 |
| HLLH | CG RAM (2) | |) | 9 | 0 | 1 | 2 | 3 | | | 4 | 5 | 6 | 7 | 8 | 9 |
| HLHL | CG RAM (3) | | * | 0 | 1 | 2 | 3 | 4 | | | 5 | 6 | 7 | 8 | 9 | 0 |
| HLHH | CG RAM (4) | | + | 1 | 2 | 3 | 4 | 5 | | | 6 | 7 | 8 | 9 | 0 | 1 |
| HHLL | CG RAM (5) | | , | 2 | 3 | 4 | 5 | 6 | | | 7 | 8 | 9 | 0 | 1 | 2 |
| HHLH | CG RAM (6) | | - | 3 | 4 | 5 | 6 | 7 | | | 8 | 9 | 0 | 1 | 2 | 3 |
| HHHL | CG RAM (7) | | . | 4 | 5 | 6 | 7 | 8 | | | 9 | 0 | 1 | 2 | 3 | 4 |
| HHHH | CG RAM (8) | | / | 5 | 6 | 7 | 8 | 9 | | | 0 | 1 | 2 | 3 | 4 | 5 |

Code H: English - Hebrew Font

| Upper 4 Bits Lower 4 Bits | LLLL | LLHL | LLHH | LHLL | LHLH | LHHL | LHHH | HLLL | HLLH | HLHL | HLHH | HHLL | HHLH | HHHL | HHHH |
|------------------------------------|------|------|------|------|------|------|------|------|------|------|------|------|------|------|------|
| | LLLL | | | | | | | | | | | | | | |
| LLLH | | | | | | | | | | | | | | | |
| LLHL | | | | | | | | | | | | | | | |
| LLHH | | | | | | | | | | | | | | | |
| LHLL | | | | | | | | | | | | | | | |
| LHLH | | | | | | | | | | | | | | | |
| LHHL | | | | | | | | | | | | | | | |
| LHHH | | | | | | | | | | | | | | | |
| HLLL | | | | | | | | | | | | | | | |
| HLLH | | | | | | | | | | | | | | | |
| HLHL | | | | | | | | | | | | | | | |
| HLHH | | | | | | | | | | | | | | | |
| HHLL | | | | | | | | | | | | | | | |
| HHLH | | | | | | | | | | | | | | | |
| HHHL | | | | | | | | | | | | | | | |
| HHHH | | | | | | | | | | | | | | | |

12-2.3 Instruction table

| Instruction | Instruction Code | | | | | | | | | | Description | Execution time (fosc=270Khz) |
|----------------------------|------------------|-----|-----|-----|-----|-----|-----|-----|-----|-----|--|---------------------------------|
| | RS | R/W | DB7 | DB6 | DB5 | DB4 | DB3 | DB2 | DB1 | DB0 | | |
| Clear Display | 0 | 0 | 0 | 0 | 0 | 0 | 0 | 0 | 0 | 1 | Write "00H" to DDRAM and set DDRAM address to "00H" from AC | 1.52ms |
| Return Home | 0 | 0 | 0 | 0 | 0 | 0 | 0 | 0 | 1 | — | Set DDRAM address to "00H" from AC and return cursor to its original position if shifted. The contents of DDRAM are not changed. | 1.52ms |
| Entry Mode Set | 0 | 0 | 0 | 0 | 0 | 0 | 0 | 1 | I/D | SH | Assign cursor moving direction and enable the shift of entire display. | 37 μ s |
| Display ON/OFF Control | 0 | 0 | 0 | 0 | 0 | 0 | 1 | D | C | B | Set display (D), cursor (C), and blinking of cursor (B) on/off control bit. | 37 μ s |
| Cursor or Display Shift | 0 | 0 | 0 | 0 | 0 | 1 | S/C | R/L | — | — | Set cursor moving and display shift control bit, and the direction, without changing of DDRAM data. | 37 μ s |
| Function Set | 0 | 0 | 0 | 0 | 1 | DL | N | F | — | — | Set interface data length (DL:8-bit/4-bit), numbers of display line (N:2-line/1-line)and, display font type (F:5x11 dots/5x8 dots) | 37 μ s |
| Set CGRAM Address | 0 | 0 | 0 | 1 | AC5 | AC4 | AC3 | AC2 | AC1 | AC0 | Set CGRAM address in address counter. | 37 μ s |
| Set DDRAM Address | 0 | 0 | 1 | AC6 | AC5 | AC4 | AC3 | AC2 | AC1 | AC0 | Set DDRAM address in address counter. | 37 μ s |
| Read Busy Flag and Address | 0 | 1 | BF | AC6 | AC5 | AC4 | AC3 | AC2 | AC1 | AC0 | Whether during internal operation or not can be known by reading BF. The contents of address counter can also be read. | 0 μ s |
| Write Data to RAM | 1 | 0 | D7 | D6 | D5 | D4 | D3 | D2 | D1 | D0 | Write data into internal RAM (DDRAM/CGRAM). | 37 μ s |
| Read Data from RAM | 1 | 1 | D7 | D6 | D5 | D4 | D3 | D2 | D1 | D0 | Read data from internal RAM (DDRAM/CGRAM). | 37 μ s |

—” : don't care

12-2.4 Timing characteristics

12-2.4.1 Write Operation

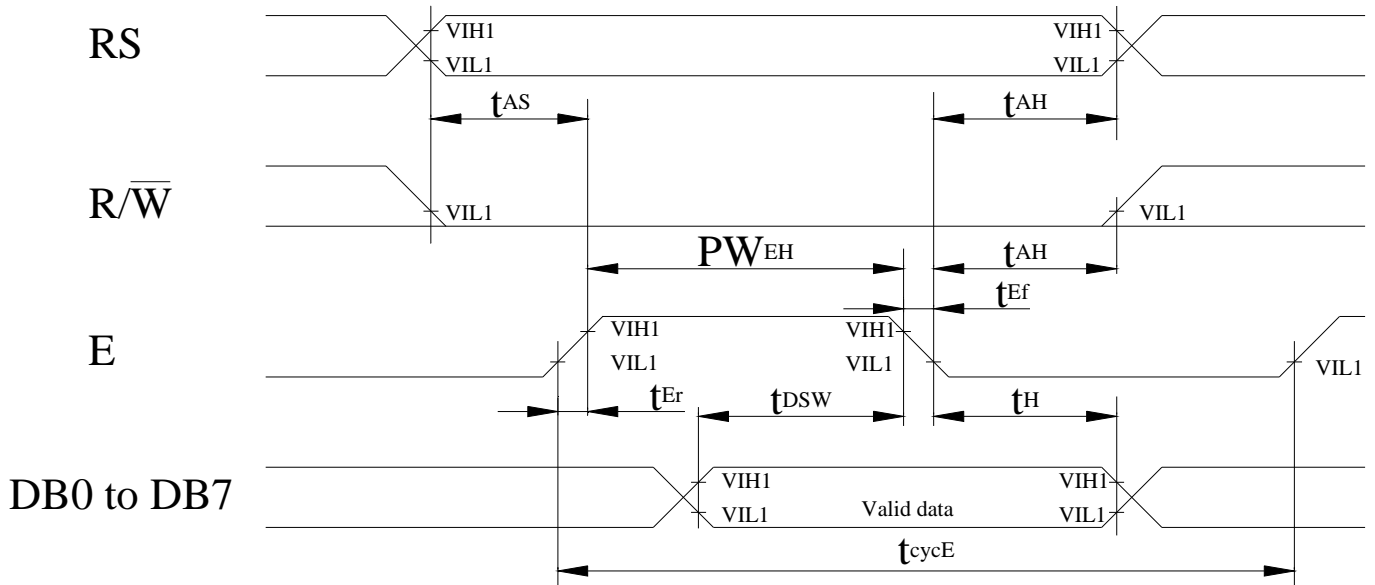

$T_a=25^{\circ}\text{C}$, $V_{dd}=5.0\pm 0.5\text{V}$

| Item | Symbol | Min | Typ | Max | Unit |
|------------------------------------|--------------------------------|------|-----|-----|------|
| Enable cycle time | t_{cycE} | 1200 | - | - | ns |
| Enable pulse width (high level) | PW_{EH} | 140 | - | - | ns |
| Enable rise/fall time | $t_{\text{Er}}, t_{\text{Ef}}$ | - | - | 25 | ns |
| Address set-up time (RS, R/W to E) | t_{AS} | 0 | - | - | ns |
| Address hold time | t_{AH} | 10 | - | - | ns |
| Data set-up time | t_{DSW} | 40 | - | - | ns |
| Data hold time | t_{H} | 10 | - | - | ns |

12-2.4.2 Read Operation

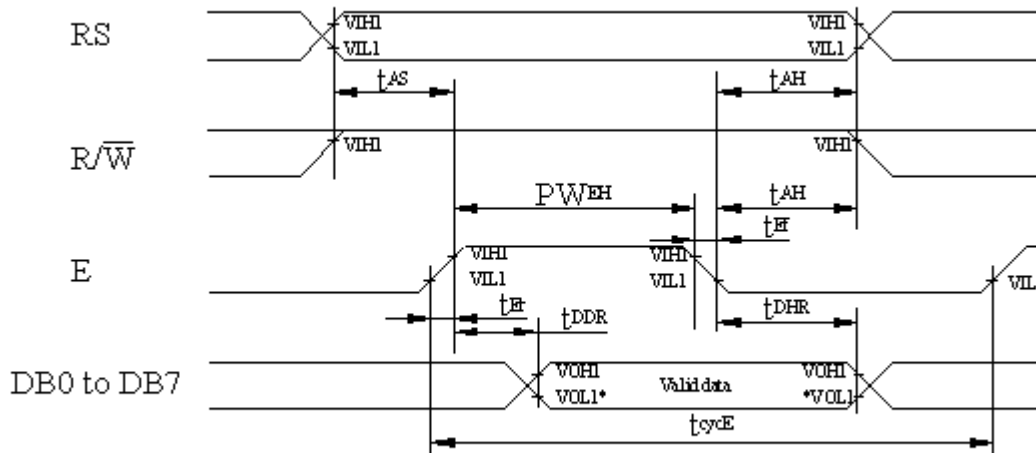

$T_a=25^{\circ}\text{C}, V_{dd}=5.0\pm 0.5\text{V}$

| Item | Symbol | Min | Typ | Max | Unit |
|------------------------------------|------------------|------|-----|-----|------|
| Enable cycle time | t_{cycE} | 1200 | - | - | ns |
| Enable pulse width (high level) | PW_{EH} | 140 | - | - | ns |
| Enable rise/fall time | t_{ER}, t_{EF} | - | - | 25 | ns |
| Address set-up time (RS, R/W to E) | t_{AS} | 0 | - | - | ns |
| Address hold time | t_{AH} | 10 | - | - | ns |
| Data delay time | t_{DDR} | - | - | 100 | ns |
| Data hold time | t_{DHR} | 10 | - | - | ns |

12-2.5 Initializing soft ware of LCM

12-2.5.1 8-bit interface

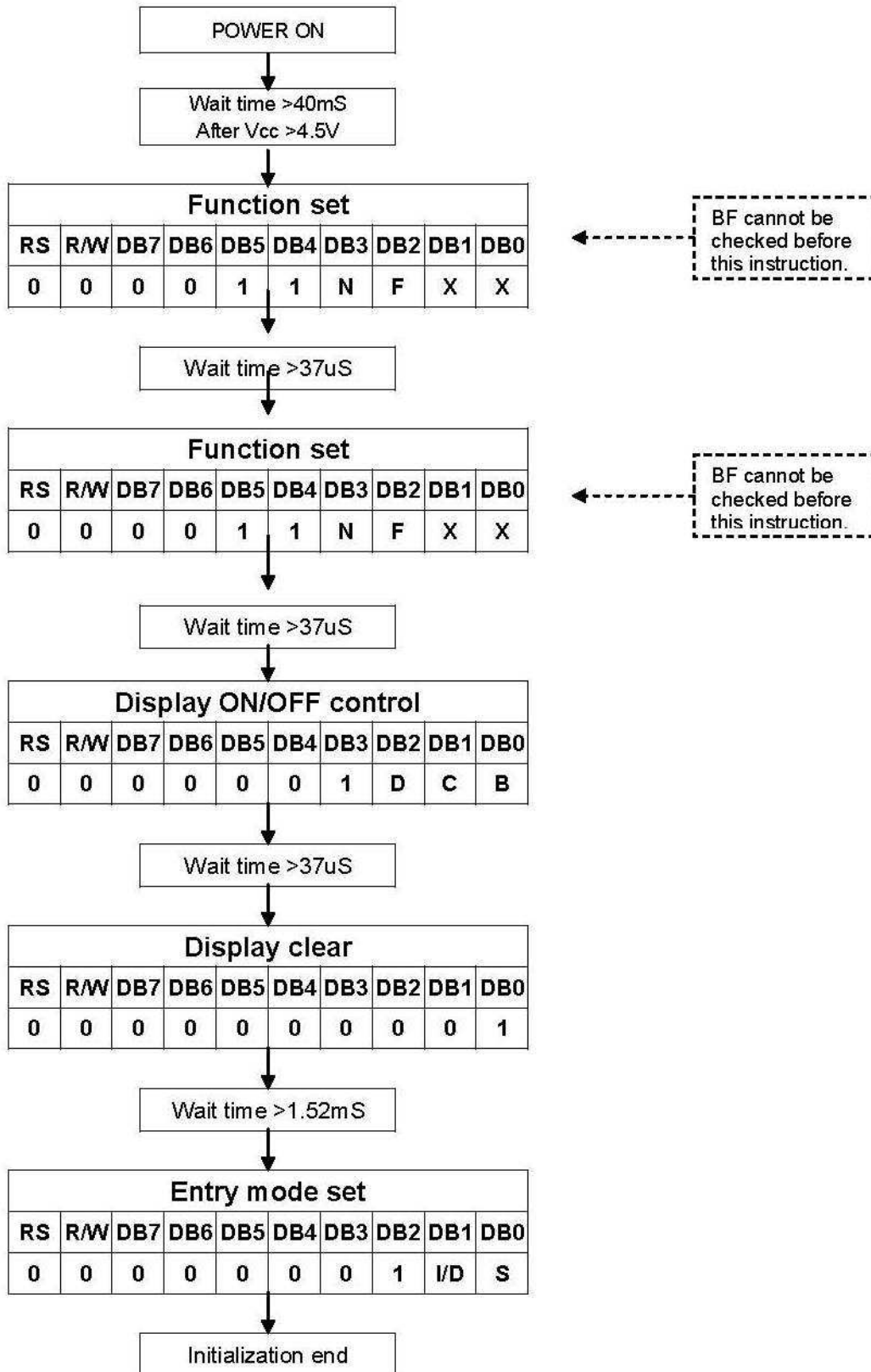

12-2.5.2 4-bit interface

